

# Thermal Model of EPC2092



# EPC2092 FEA thermal simulation



- The thermal model applies to EPC2092.
- A power dissipation of 1 W in the device active area is assumed.
- Finite element analysis (FEA) thermal simulations
  - $R_{\Theta JB}$  and  $R_{\Theta JC}$  are obtained by stationary simulations.
  - $Z_{\Theta JB}$  and  $Z_{\Theta JC}$  are obtained by transient simulations.
- R-C thermal model is generated.

# Steady-state $R_{\Theta JB}$

- Example:  $P = 1 \text{ W}$

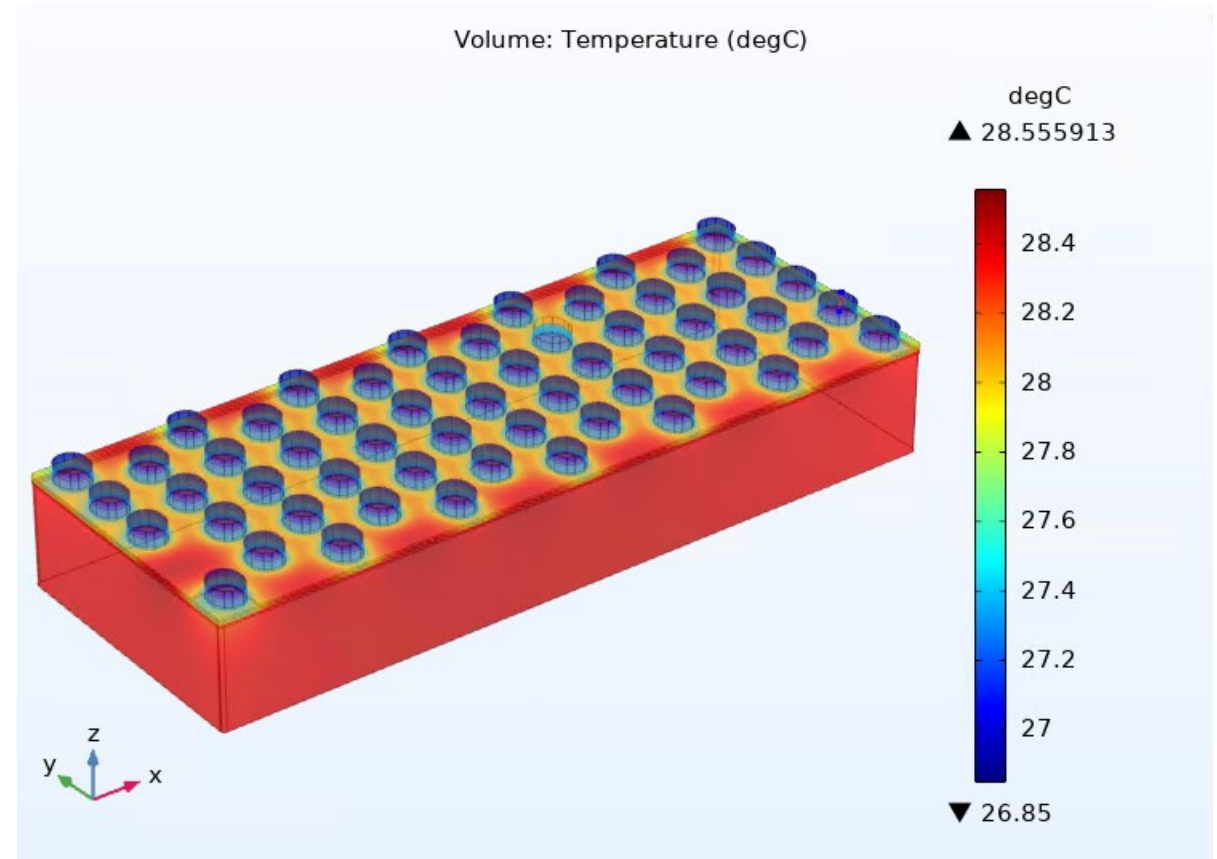

# Steady-state $R_{\theta Jc}$

- Example:  $P = 1 \text{ W}$

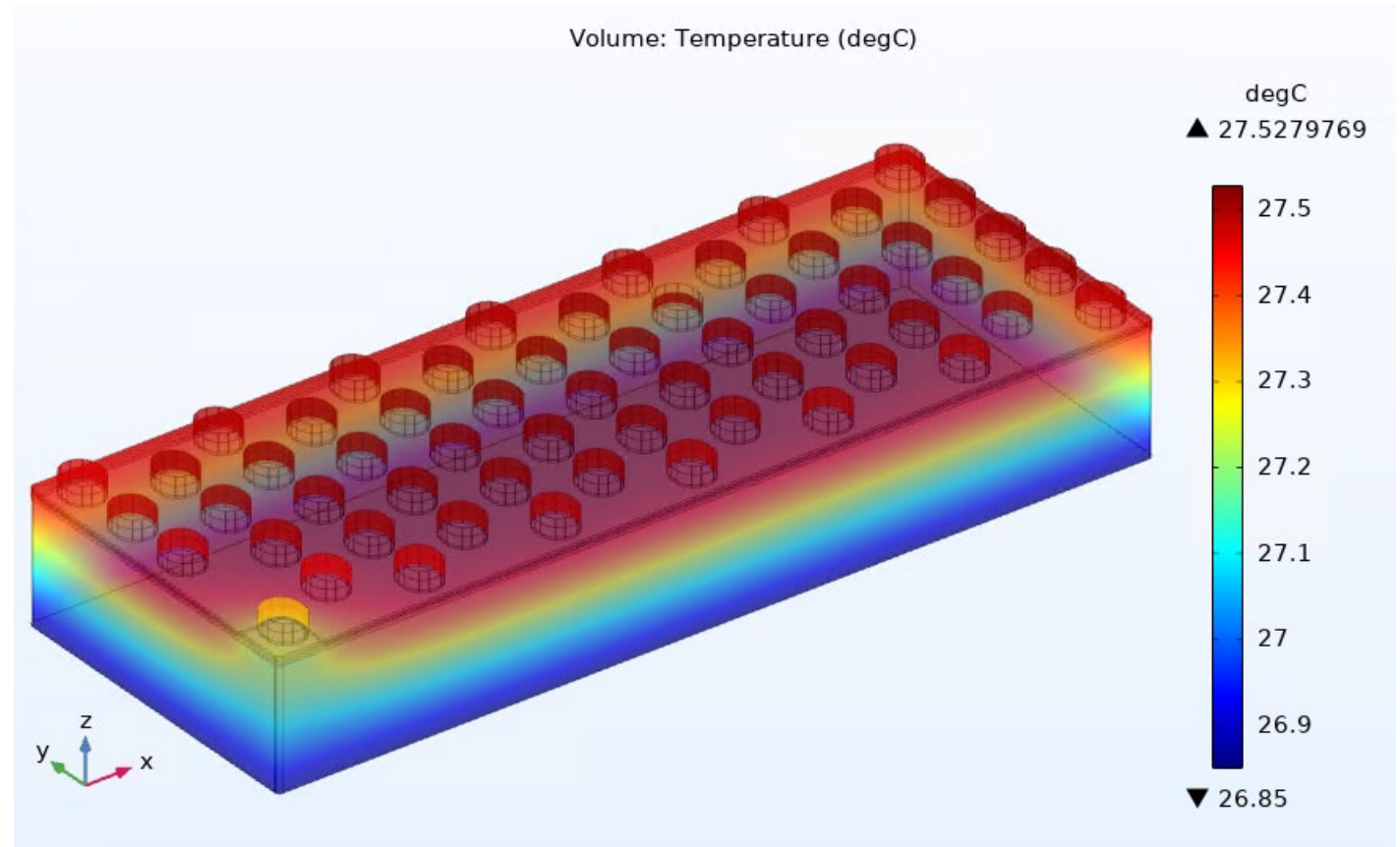

# $Z_{\Theta JB}$ R-C thermal model

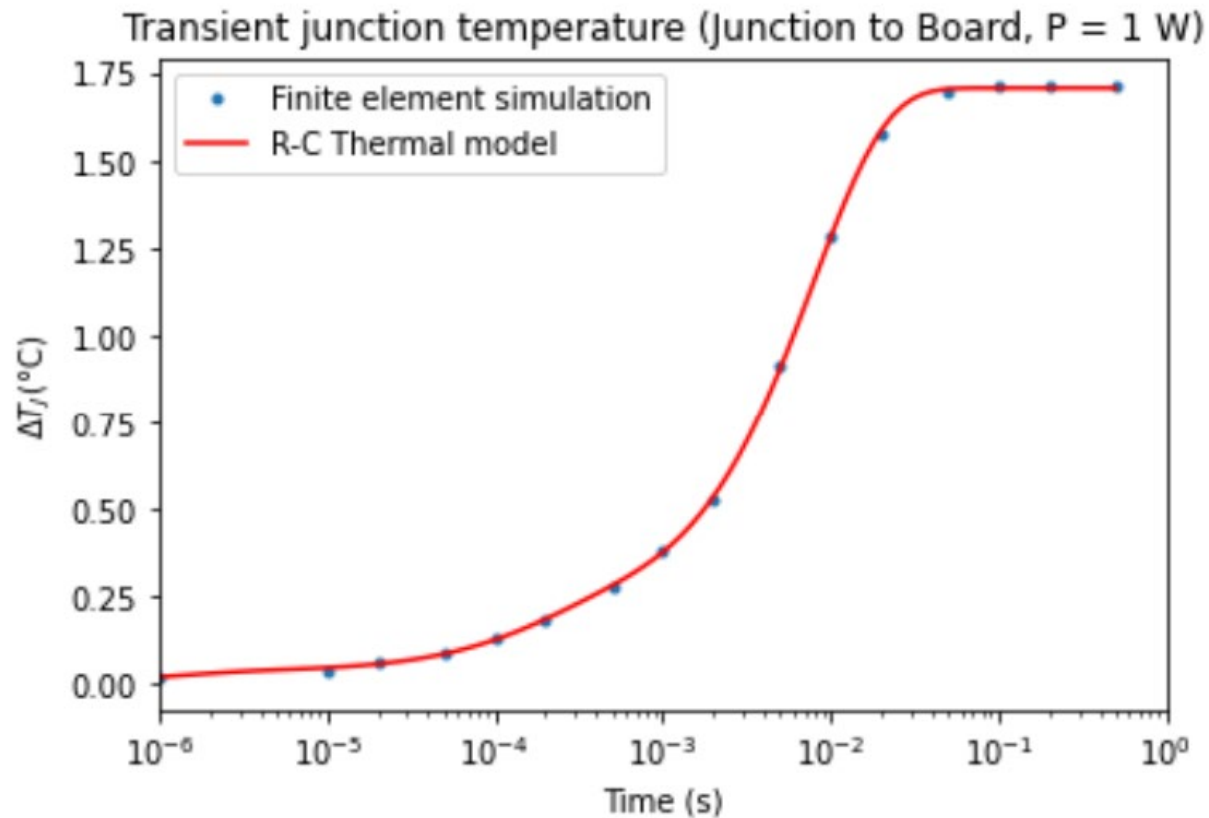

Model Parameter	Value	Unit
Rth1	3.53E-02	°C/W
Rth2	1.63E-01	
Rth3	1.51E+00	
Cth1	3.73E-05	J/°C
Cth2	1.05E-03	
Cth3	5.25E-03	

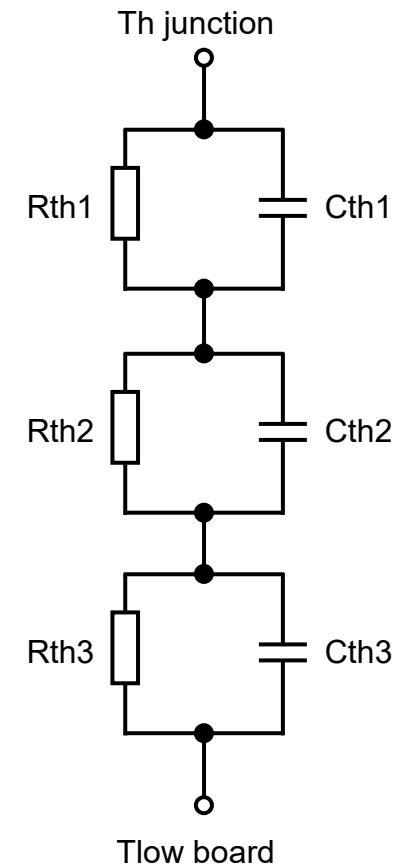

# $Z_{\Theta JC}$ R-C thermal model

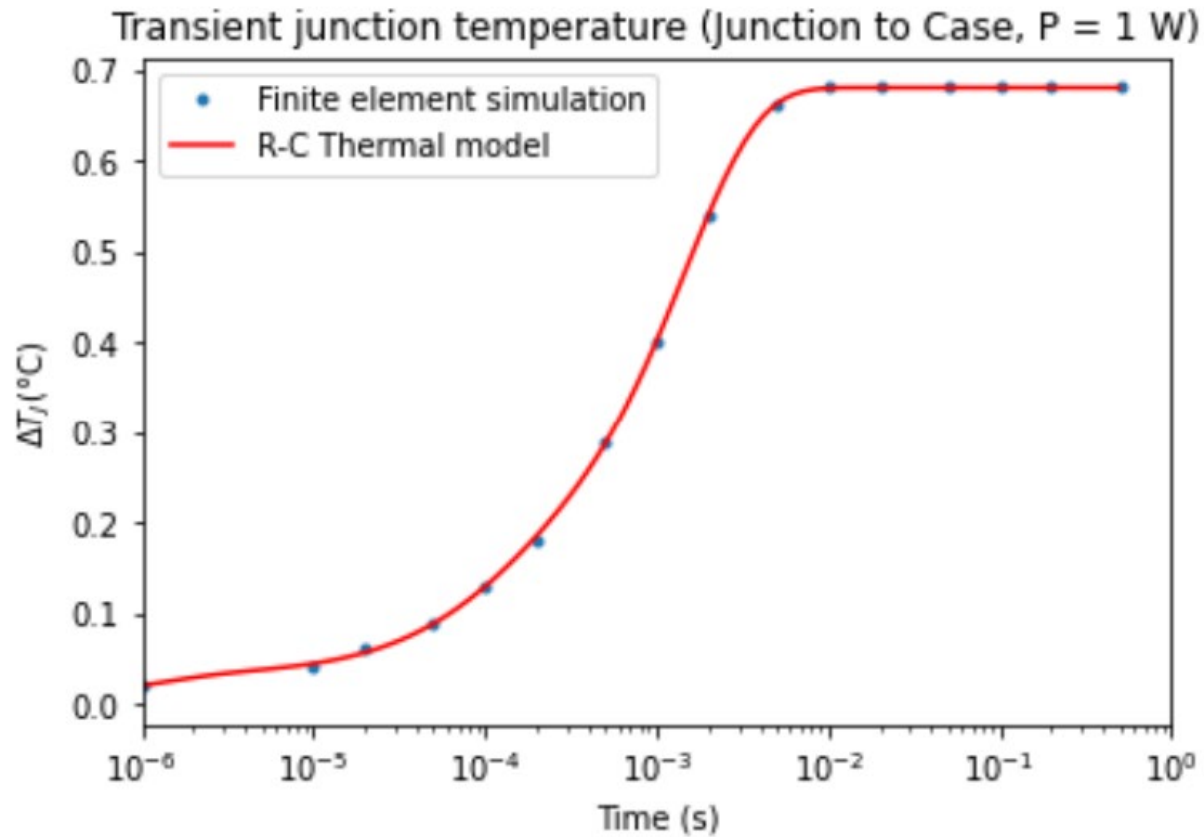

Model Parameter	Value	Unit
Rth1	3.11E-02	°C/W
Rth2	9.43E-02	
Rth3	5.54E-01	
Cth1	3.52E-05	J/°C
Cth2	1.02E-03	
Cth3	2.62E-03	

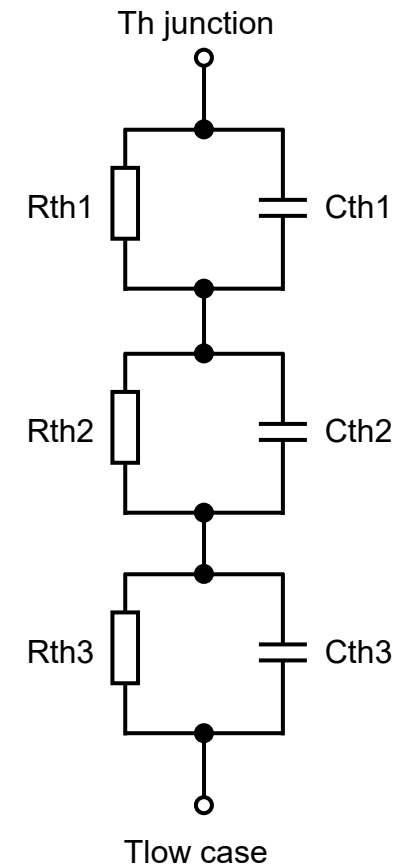



How To GaN Video Series

[epc-co.com](http://epc-co.com)

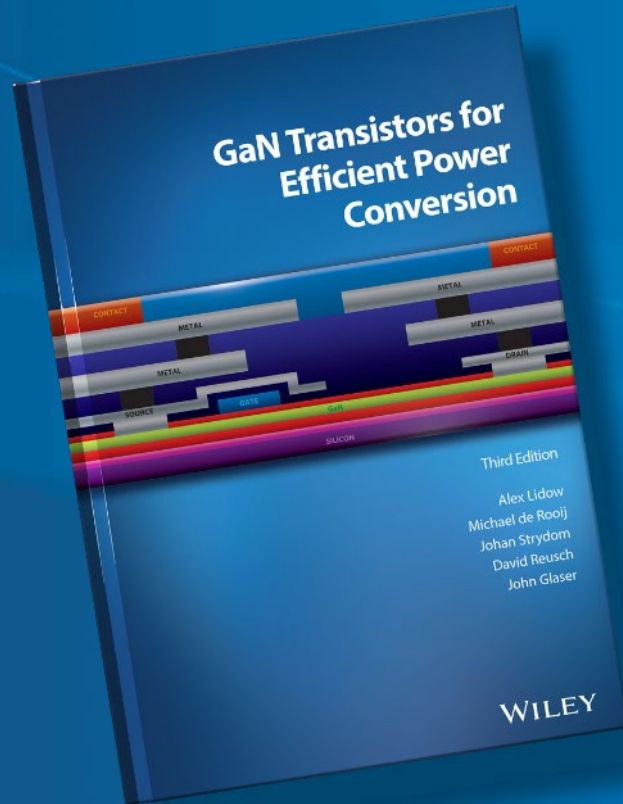

3<sup>rd</sup> Edition Textbook

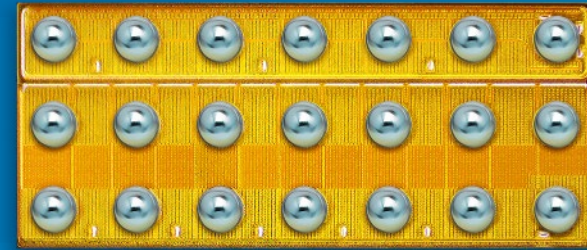

eGaN<sup>®</sup> FETs and ICs

Evaluation  
Kits

